

Operating Instructions: Holland Tri-Lo Chock Vehicle Securement System

Loading Procedure

1. Remove a short-strap and long-strap chock from storage bins.
2. Take care not to contact the body of vehicles with any part of chock system during loading and unloading.

3. Place first chock as shown on the chock tie-down track as close as possible to the tire.

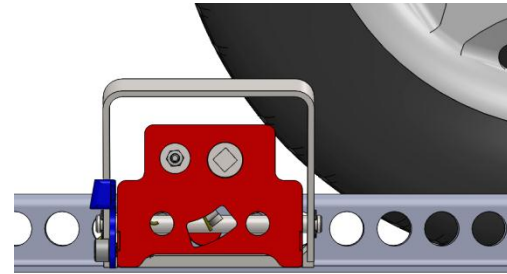

4. Push down on handle to lock chock securely to the chock tie-down track.

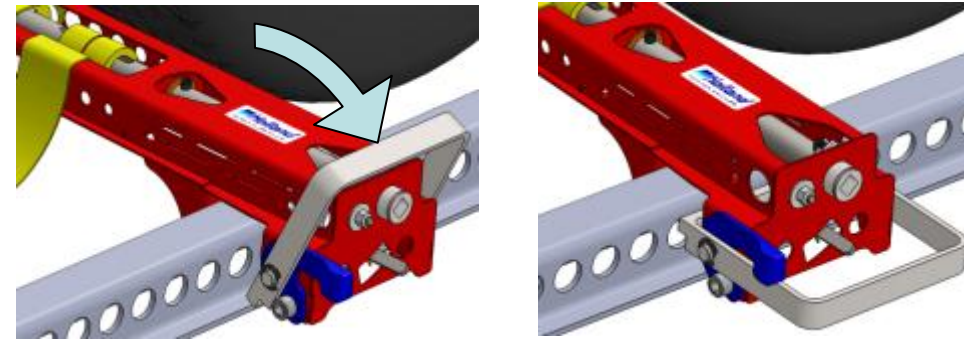

5. Bring long strap with buckle over tire and attach to short strap end. Place cleat ridges in tire tread. Hook points away from tire as shown.

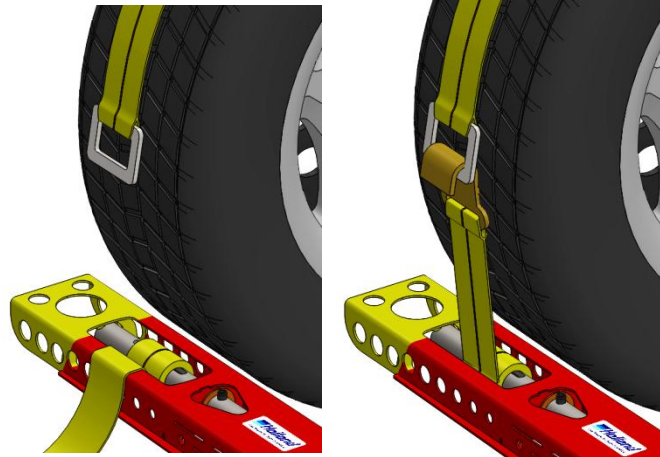

6. Use 1/2" drive ratchet to tighten winch, rotate counter-clockwise. Take up slack on both sides, then tighten two more clicks.

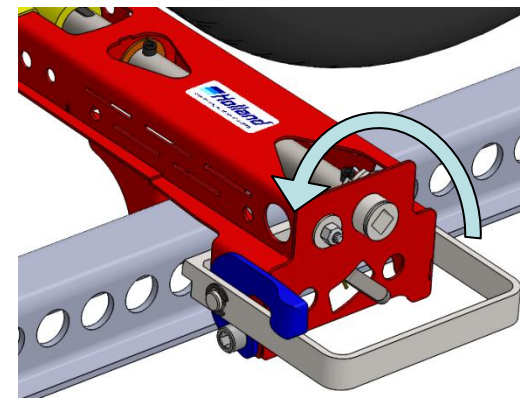

Correct chock placement

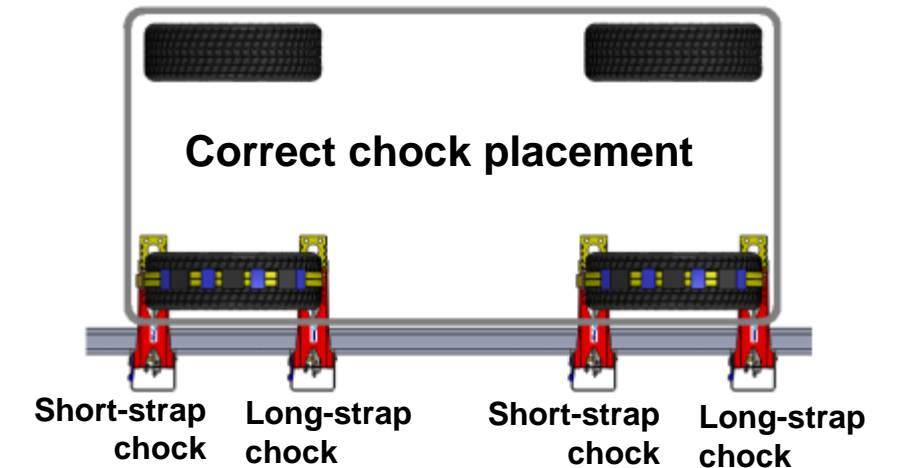

Unloading Procedure

1. Push back on lever to increase slack in straps.

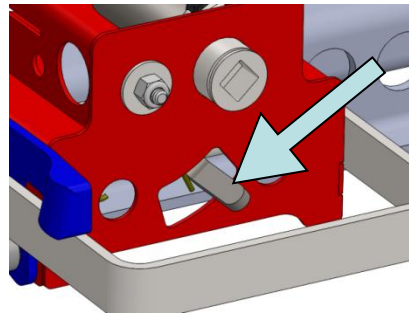

2. Unhook strap coupling and remove straps from tire.

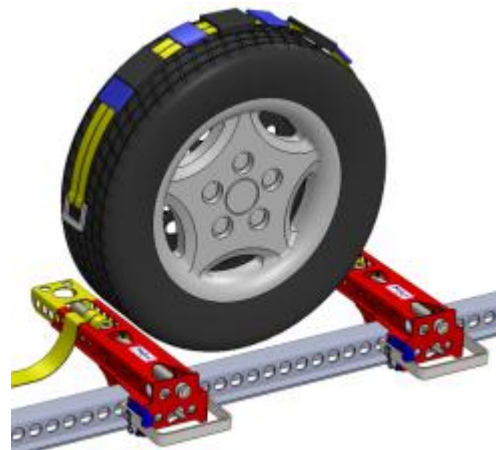

3. While plastic tab is pushed in, lift up handle and remove chock.

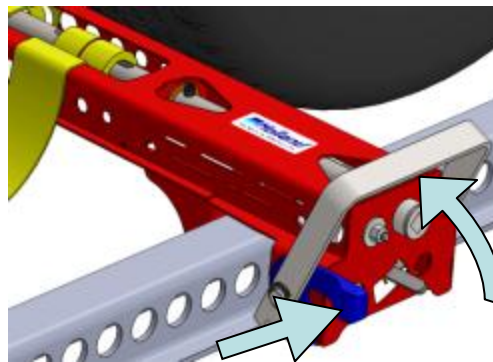

4. Wrap strap around chock body. Repeat unloading procedure for all chocks and place in storage bins. Make sure any loose straps are placed securely in bins.

Strap Replacement

1. Insert hemmed end of strap completely through slots in tube, use wider slot first.
2. Wrap end back around to wider slot, and insert hem.
3. Make sure hemmed part of strap grabs inside wall of tube. If it does not, then wrap around the tube in the opposite direction.

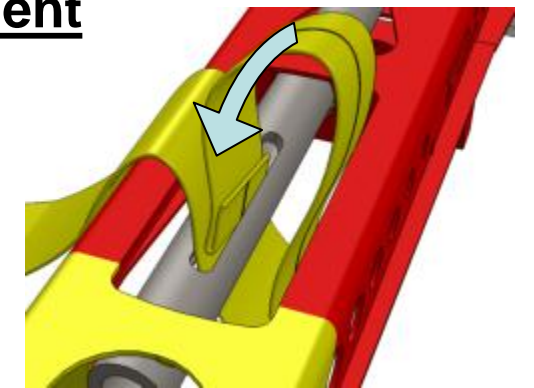

1000 Holland Drive
Crete, IL 60417-2120
Phone: (708) 672-2300
www.hollandco.com

Tri-Lo Chock w/ LONG Strap, p/n 74680
Tri-Lo Chock w/ SHORT Strap, p/n 74670